

**REGISTRATION / INSTALLATION  
GUIDE**

**M I N I H 3 G**

**trackmate**<sup>gps™</sup>  
Real Time GPS Tracker

**[WWW.TRACKMATEGPS.COM](http://WWW.TRACKMATEGPS.COM)**

## WELCOME!

Welcome to a new dimension of safety and security for your vehicles with your purchase of the TrackmateGPS MINI H 3G and its advanced technology. You are now able to have control of your vehicles, whether you operate a business with company cars, a fleet of limousines, or you are a parent of a teenage driver. The MINI H 3G lets you know where your car is at all times. It can even signal you if someone exceeds your pre-determined speed limit or enters an area you you'd rather him/her not be there.

The MINI H 3G is ideal for commercial or personal use, simple to install and easy to use.

***\*Read this Registration / Installation Guide carefully before installing your new MINI H 3G.***

## STEP ONE: Registration and Activation

Before you turn on or install your MINI H 3G, you must create an account, and register your device(s) on our website. At the LOGIN page, you will be given the option "REGISTER". Simply fill out the account information form. Next, you will be prompted to select one of the service plans: SAVER, BASIC, PREMIUM or PLATINUM. After selecting a service plan you will be prompted to enter your credit card information.

You will now be redirected to the home page where you will be able to enter the device's 15 digits IMEI number which can be found on the foil label on the back of the device. You must

select the country where your device is located. Failing to provide the correct information will cause the activation to fail.

## STEP TWO: Installation

Estimated time required for installation: 30 to 45 minutes for experienced installer – 1 to 2 hours for novice.

- It is recommended you use a professional car electrician to install your tracker. However, if you're handy, you may choose to install it on your own. Tools needed for installation: voltage tester/meter, wire stripper, electrical tape, wire connectors, fuse taps (optional)
- The tracker has to be connected to a power source providing 9V-30V DC. The wiring must be connected to constant power for correct tracking. Standby power consumption is minimal at < 5 mA and should not affect your vehicle battery, unless the vehicle is not used for an extended period (several weeks) or the vehicle battery is in poor condition.

*Relay Diagram*

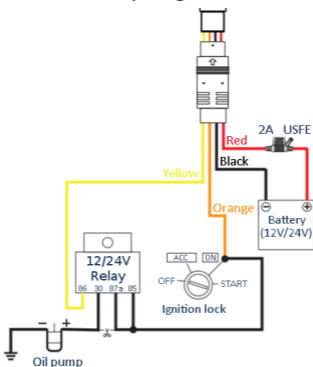

- The wiring harness has four wires (approximately 6ft long). Plug the wiring harness to the device. Strip the black wire and ground it securely. The red wire should be connected to a constant power source (fuse or wire) providing between 9V and 30V. Finally, the orange wire has to be connected to ignition/accessory or any fuse/wire which is powered by ignition. The yellow wire can be used to remotely control the ignition by installing a relay.
- **LED lights indicators:** the MINI H 3G is shipped with its back cover opened in order to facilitate the activation process. You'll notice a small ON/OFF switch next to the SIM card that should be positioned to ON. The device has three LED lights, green, blue and red. Approximately 10 seconds after switching the device ON, the LED lights will start flickering. The green light indicates the status of the GSM (cellular) connection. It will go through various sequences, such as solid light, rapid flashing, reduced flashing and finally, a steady light. The red light indicates that the device has either internal or external battery power. Finally, the blue light indicates the GPS status. When all lights are steady the GPS position is acquired. Flashing every few seconds indicates that the GPS module is on standby.
- You can test your device before actually installing it by powering it up and checking the "Test/Installed" box online. You will receive an email or SMS displaying the location on a Google map. Once this is completed, the activation process begins automatically. In order for your device be able to start tracking it must be outdoors and not indoors. Your device will usually start tracking within the hour. You can uncheck the "Test/installed" box if you don't intend to finish your installation on the same day.

- Optimal installation locations are below the dashboard, behind the glove compartment or radio. The device must be positioned horizontally, with the light sensor (small rectangular box in center of back) and label with IMEI number pointing down. The wire must be towards the rear of the vehicle. It is critical that your device is not obstructed by thick metal. Installing in the engine compartment is not recommended, because of the extreme temperatures which can affect performance of the device.

***In the event the tracker does not begin tracking, please contact us by phone at 718-878-4056 or email us at support@trackmategps.com with your username in the subject line. We will assist you promptly.***

## FREE TRIAL PERIOD

Your purchase includes a free trial period for 7 days from the date of your tracking. At time of registration the quarterly fee will be put on hold on your credit card (please note that the free trial period does not apply to any additional devices that you add to the account).

***No contract or service agreement is required. The tracking fee is billed automatically every three months for each active device. No-fee cancellation can be done online 24/7. Prepaid tracking fees of greater than one month will be refunded.***

## OTHER IMPORTANT INFORMATION

Most electronic devices that rely on software to operate occasionally become unresponsive (freeze) and require re-booting. This reboot can in most instances be done remotely by us. However, occasionally the device has to be rebooted manually.

Manual reboot instructions: 1) Remove back from device by inserting a flat-head screwdriver in the small indentation opposite the wiring harness and thereby lifting the cover. Verify the LED lights on your device. In the event the LED lights are not on, you most probably have a wiring issue. Your next step should be to inspect the fuse in the wiring harness. If your fuse is OK, you should verify the voltage of the wiring with a multi-meter 2) If the LED lights are on, simply slide the ON/OFF switch to the OFF position for 20 seconds, then turn device ON again. This action will reboot your device. In the rare event that the issue wasn't resolved, feel free to contact us for any assistance or troubleshooting.

When you activate your MINI H 3G unit, you acknowledge and accept the terms and conditions of the service agreement. Should you discontinue service, your SIM will be de-activated. Re-activating your service might carry a \$20 fee.

***We reserve the right to occasionally replace the SIM card in your device for improved tracking.***

## THANK YOU!

Thank you for purchasing the TrackmateGPS™ MINI H 3G. We are confident you will find the service and features a valuable part of your personal or professional life. If you have any questions, please feel free to contact us at:

**[support@trackmategps.com](mailto:support@trackmategps.com)**

[WWW.TRACKMATEGPS.COM](http://WWW.TRACKMATEGPS.COM)

**trackmate**<sup>gps</sup>  
Real Time GPS Tracker